

DETAIL OF NOTCH FROM SECTION A-A
SCALE: 3/4"=1'-0"

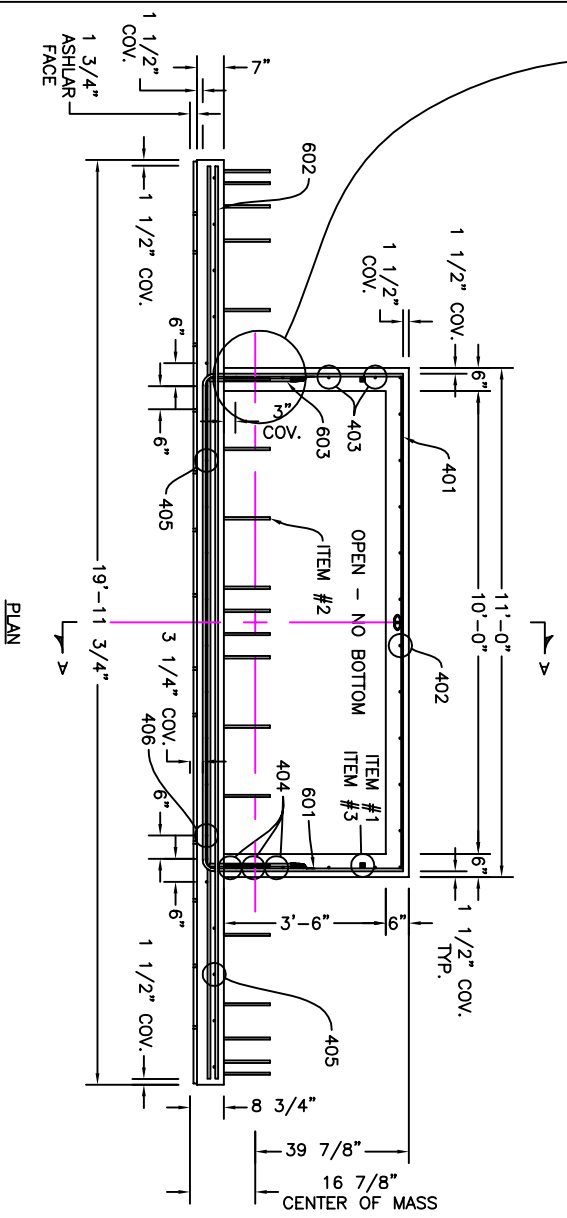

PLAN

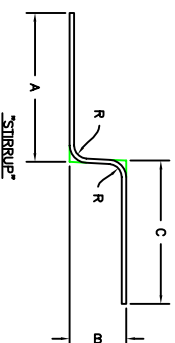
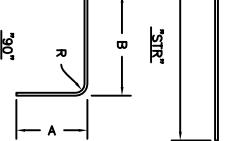
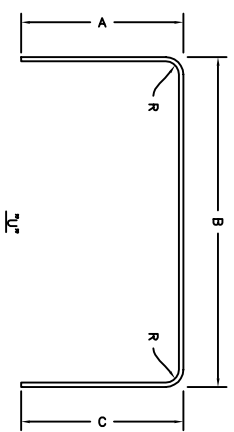
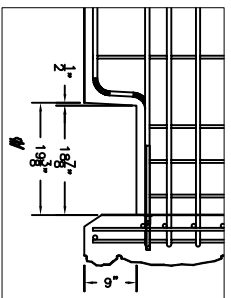
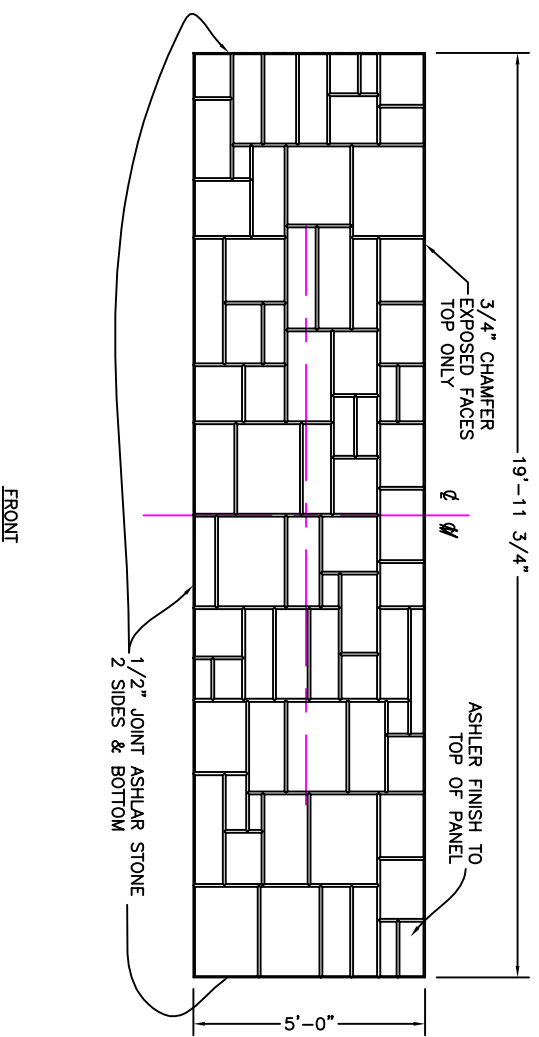

FRONT

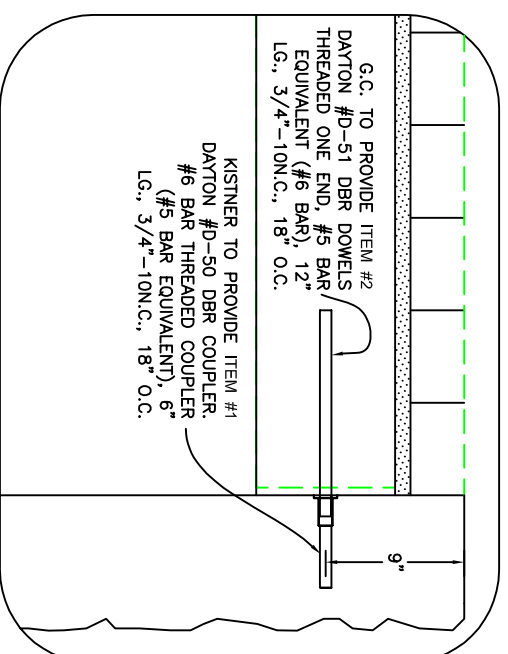

EVERGREEN COUPLER DETAIL
SCALE: N/A

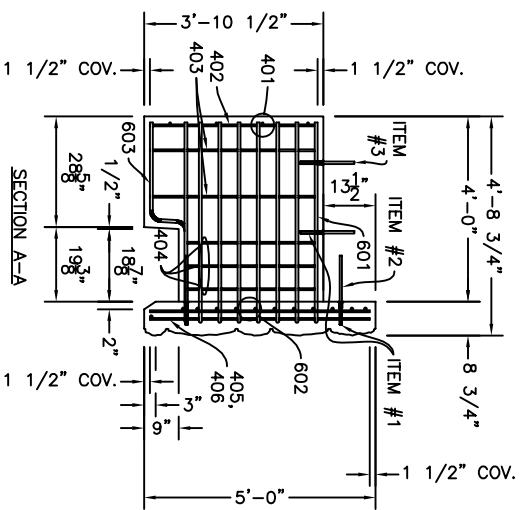

SECTION A-A

4 TON FLEET LIFT SYSTEM, RQ-75 WITH #4 BAR TENSION ROD (SHOWN BELOW) FOR STRIPPING PIECES FROM FORMS AND SETTING.

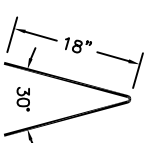

LIFT DETAIL, PLAN

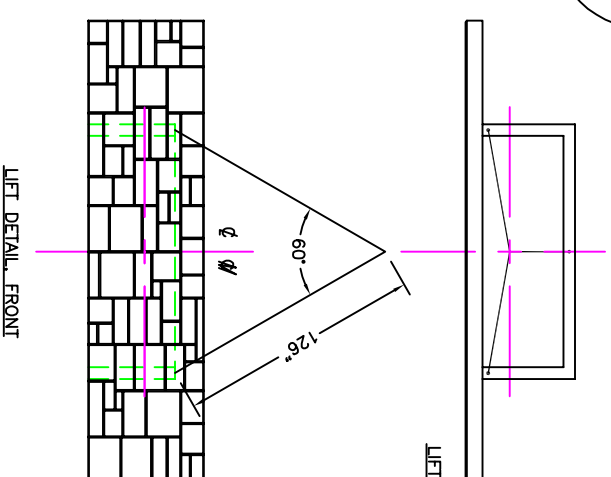

LIFT DETAIL, FRONT

LIFT DETAIL, END

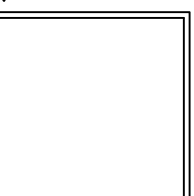

REVISIONS	PROJECT:	EVERWALL MAX PIER APPLICATION
	LOCATION:	
	OWNER:	
	ENGINEER:	
	CONTRACTOR:	
	MANUFACTURER:	
	PRODUCT DESIGNATION:	
	SCALE:	
	DRAWN BY:	
	CHECK 1:	
	CHECK 2:	