

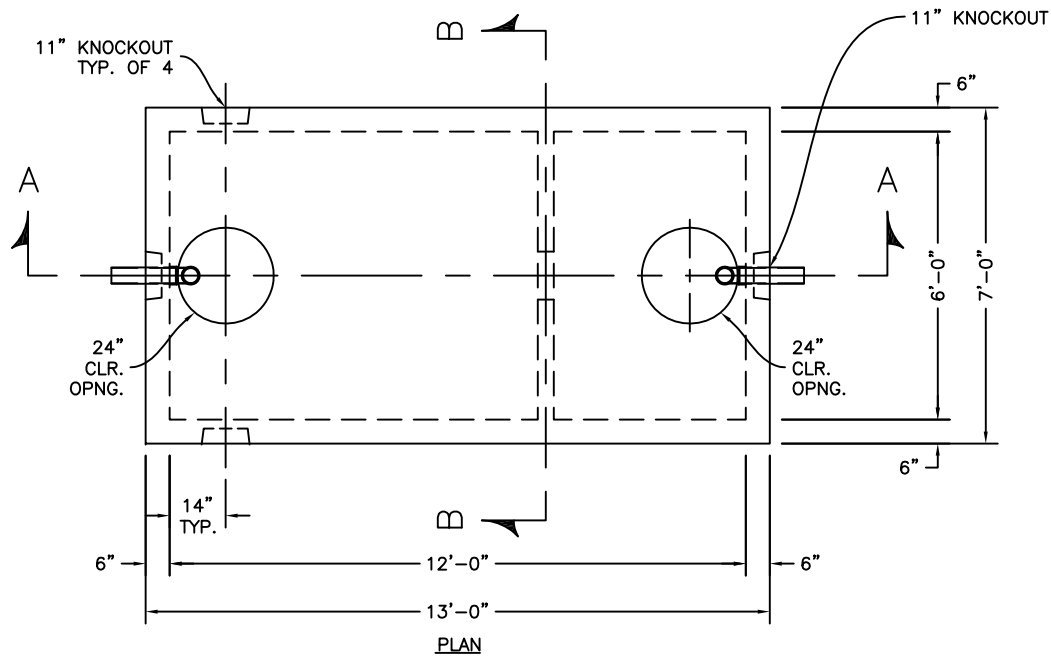

KISTNER CONCRETE PRODUCTS, INC.
8713 READ ROAD
E. PEMBROKE, N.Y.
14056
(716) 894-2267

PRODUCT DESIGNATION
2500 GAL. SEPTIC TANK/TRAFFIC

DWG. NO.
ST-ST2500T
9/7/12



SP-7A
SPECIFICATIONS:
CONCRETE: 5,000 P.S.I. @ 28 DAYS.
ENTRAINED AIR: 5% - 8%.
STEEL: A.S.T.M. A496-A615
GRADE 60-80 KSI.
ACI 318-99 TRAFFIC. USE ACI LOAD FACTORS.
A.A.S.H.T.O. METHOD OF DESIGN. EQUIVALENT SOIL PRESSURE OF 40 (PCF).
DESIGN LOADING:
LIVE LOAD: H20.
EARTH FILL: 0 TO 6'.
WATER TABLE: 3' BELOW GRADE.

WEIGHT:
TOP SECTION: 16,712 LBS.
BOTTOM SECTION: 22,000 LBS.
TOTAL: 38,712 LBS.
BAFFLE: 4" BY KISTNER. LARGER BY CONTRACTOR.

WATERTIGHT ASSEMBLY IS THE RESPONSIBILITY OF THE INSTALLING CONTRACTOR. ASK FOR KISTNER "WATERTIGHT JOINT INSTALLATION" DETAIL.

- PIPE OPENINGS STOCK:
- PIPE SEALS REQUIRED
 - 4" PVC - OPENING WITH SEAL - STOCK
 - 6" PVC - OPENING STOCK - SEAL TO BE INSTALLED
 - 8" PVC - OPENING STOCK - SEAL TO BE INSTALLED
 - GROUTED OPENINGS ONLY - REQUIRED
 - 4" PVC - OPENING WITH SEAL - STOCK
 - 6" PVC - STOCK KNOCKOUT TO BE BROKEN OUT BY CONTRACTOR
 - 8" PVC - STOCK KNOCKOUT TO BE BROKEN OUT BY CONTRACTOR

