

SPECIFICATIONS:

CONCRETE: 4,000 PSI @ 28 DAYS
 ENTRAINED AIR: 5% - 9%
 STEEL: ASTM A495-A615
 GRADE 60-60KSI

KISTNER CONCRETE PRODUCTS, INC. STOCKS
 RIGHT OF WAY MARKERS IN TWO DIFFERENT
 HEIGHTS- L-TYPE @ 4'-0" AND H-TYPE @
 6'-4" WITH COPPER PIN CAST IN TOP. PLEASE
 SPECIFY LETTERING.

ITEM#: 625.03
 CODE: HP-ROW-L WEIGHT: - 117 LBS.
 HP-ROW-H WEIGHT: - 187 LBS.

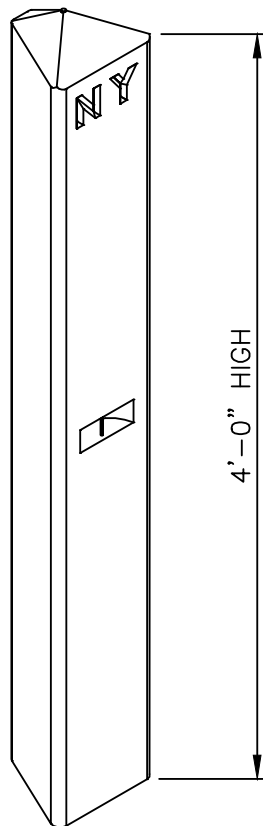
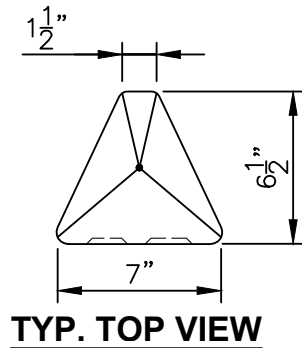

**L-TYPE
 RIGHT OF WAY MARKER**

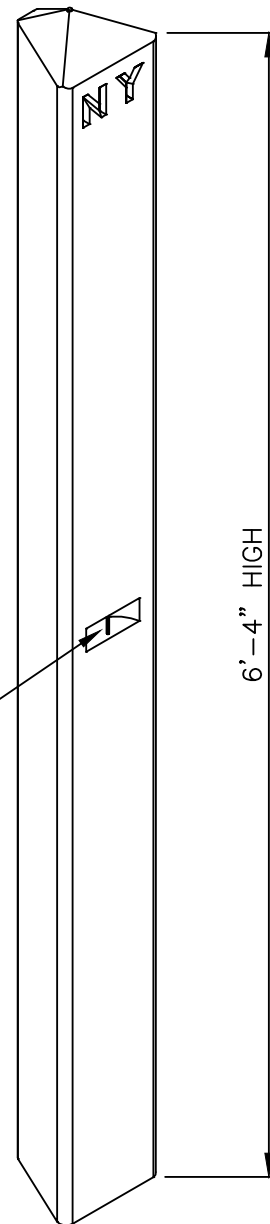

**H-TYPE
 RIGHT OF WAY MARKER**

RECESSED 1-TON
 LIFT LOOP (TYP.)

DATE: 5/15/19	PROJECT: KCP INHOUSE RIGHT OF WAY MARKERS	SHEET TITLE: RIGHT OF WAY MARKER DETAIL SHEET	SHEET NO: 01
SCALE: N.T.S.			DWG. NO: RoW-MKR_R0
	5550 HINMAN ROAD LOCKPORT, NEW YORK 14094 PHONE 716-434-6157		DRAWN BY: MAK
		REV. NO. DATE DESCRIPTION	CK'D BY: MJK