



KISTNER CONCRETE
PRODUCTS INC.
8713 READ ROAD
E. PEMBROKE, N.Y.
14056
(716) 894-2267

PRODUCT DESIGNATION

DWG. NO.

HEAVY DUTY 6' PARKING BUMPER

PRKB-6HD

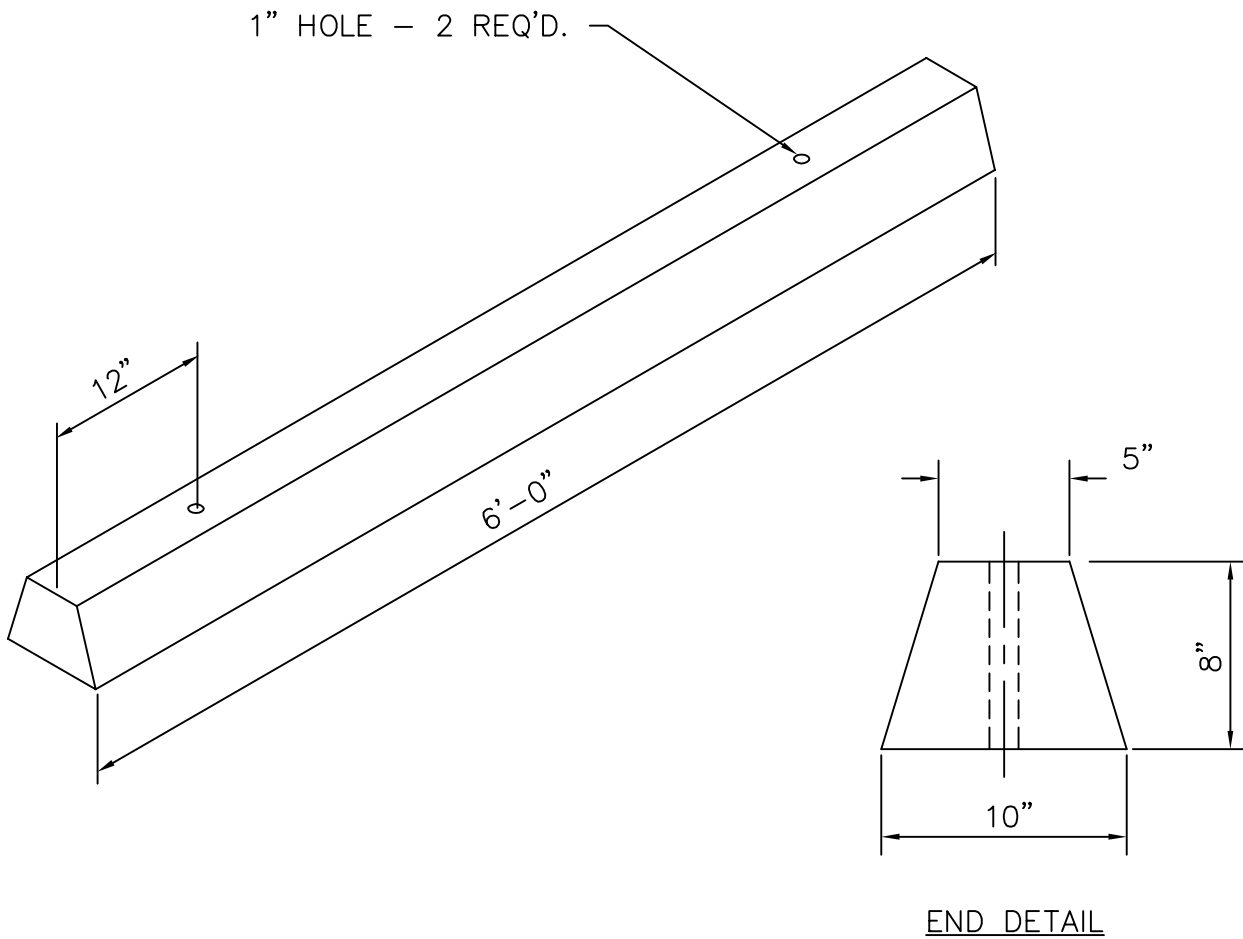

SPECIFICATIONS:

CONCRETE: 4000 P.S.I. @ 28 DAYS.
ENTRAINED AIR: 5% - 9%.
STEEL: A.S.T.M. A496-A615
GRADE 60-60 KSI.
WEIGHT: 360 LBS.