

TOP VIEW

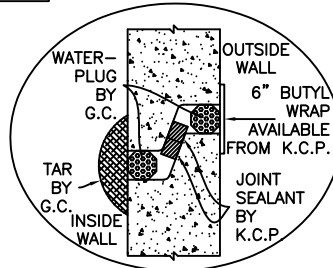

WATERTIGHT JOINT DETAIL
SCALE: N/A

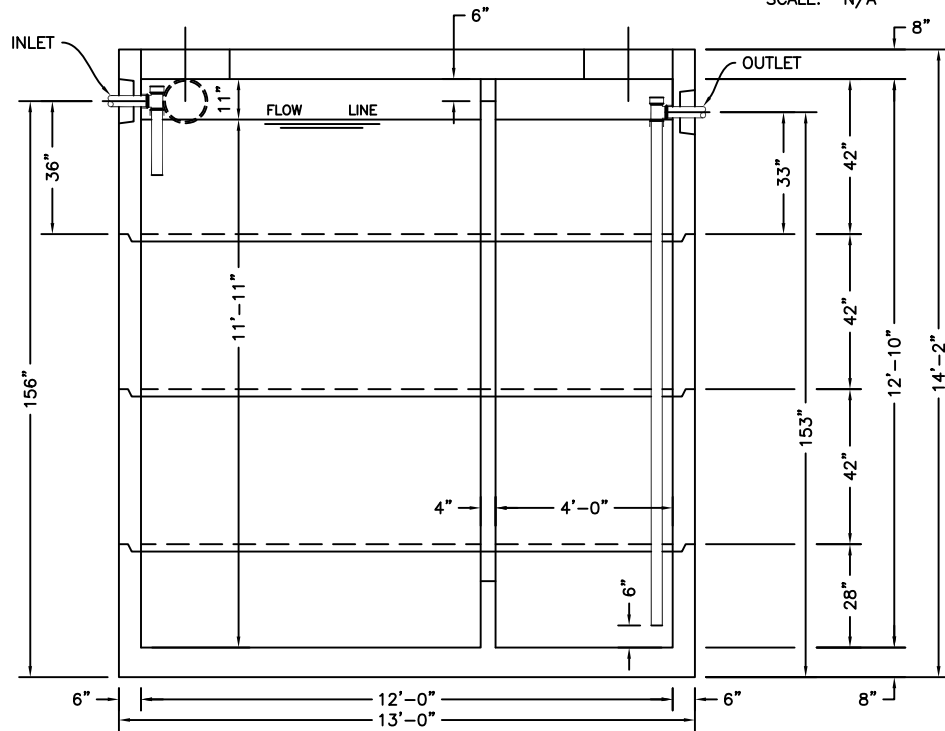

SECTION A-A

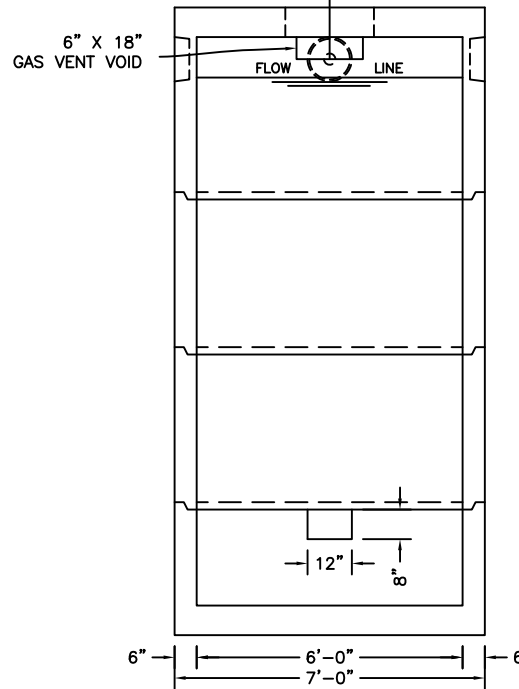

SECTION B-B

SP-7A
SPECIFICATIONS:
 CONCRETE: 5,000 P.S.I. @ 28 DAYS.
 ENTRAINED AIR: 5% - 8%.
 STEEL: A.S.T.M. A496-A615 GRADE 60-80 KSI.
DESIGN LOADING: ACI 318-99 TRAFFIC. USE ACI LOAD FACTORS. A.A.S.H.T.O. METHOD OF DESIGN. EQUIVALENT SOIL PRESSURE OF 40 (PCF).

LIVE LOAD: H20.
EARTH FILL: 0 TO 3'.
WATER TABLE: 3' BELOW GRADE.

WEIGHT:
 TOP SECTION: 20,704 LBS.
 MID-SECTION: 11,935 LBS.
 BOTTOM SECTION: 18,007 LBS.
 TOTAL: 62,581 LBS.

PIPING: TEES, DROP LEGS & FITTINGS SUPPLIED AND INSTALLED BY G.C.

WATERTIGHT ASSEMBLY IS THE RESPONSIBILITY OF THE INSTALLING CONTRACTOR. ASK FOR KISTNER "WATERTIGHT JOINT INSTALLATION" DETAIL.

PIPE OPENINGS STOCK:

- PIPE SEALS REQUIRED
 - 4" PVC - OPENING WITH SEAL - STOCK
 - 6" PVC - OPENING STOCK - SEAL TO BE INSTALLED
 - 8" PVC - OPENING STOCK - SEAL TO BE INSTALLED
- GROUTED OPENINGS ONLY - REQUIRED
 - 4" PVC - OPENING WITH SEAL - STOCK
 - 6" PVC - STOCK KNOCKOUT TO BE BROKEN OUT BY CONTRACTOR
 - 8" PVC - STOCK KNOCKOUT TO BE BROKEN OUT BY CONTRACTOR



KISTNER CONCRETE PRODUCTS, INC.
 8713 READ ROAD
 E. PEMBROKE, N.Y.
 14056
 (716) 894-2267

6000 GAL. OIL SEPARATOR - TRAFFIC

OS-OS6000T
 4/2/19
 DWG. NO.