



KISTNER CONCRETE PRODUCTS INC.
8713 READ ROAD
E. PEMBROKE, N.Y.
14056
(716) 894-2267

PRODUCT DESIGNATION

MANHOLE 6' DIA. PUMP STATION

DWG. NO.

MH6PS ©
5/23/12

GENERAL NOTES:

1. REINFORCED STEEL CONFORMS TO ASTM A185 SPEC. 0.18 in²/LF AND 0.18 in²/LF B/W IN BOT. SLAB.
2. CONCRETE COMPRESSIVE STRENGTH 4,000 PSI. MINIMUM.
3. MANHOLE DESIGN SPECIFICATIONS CONFORM TO LATEST ASTM C478 SPEC. FOR PRECAST REINFORCED CONCRETE MANHOLE SECTIONS.
4. ONE POUR MONOLITHIC BASE SECTION.
5. HATCHES DESIGNED FOR H-20 WHEEL LOADS ARE NOT MEANT TO BE SUBJECTED TO HIGH DENSITY TRAFFIC OR TO BE PLACED IN DELIBERATE TRAFFIC AREAS. RECOMMEND GALVANIZED STEEL HATCHES FOR THOSE APPLICATIONS.
6. LIFTERS ARE RECESSED IN TOP SURFACE OF UNITS WITH HATCHES CAST IN FLUSH.

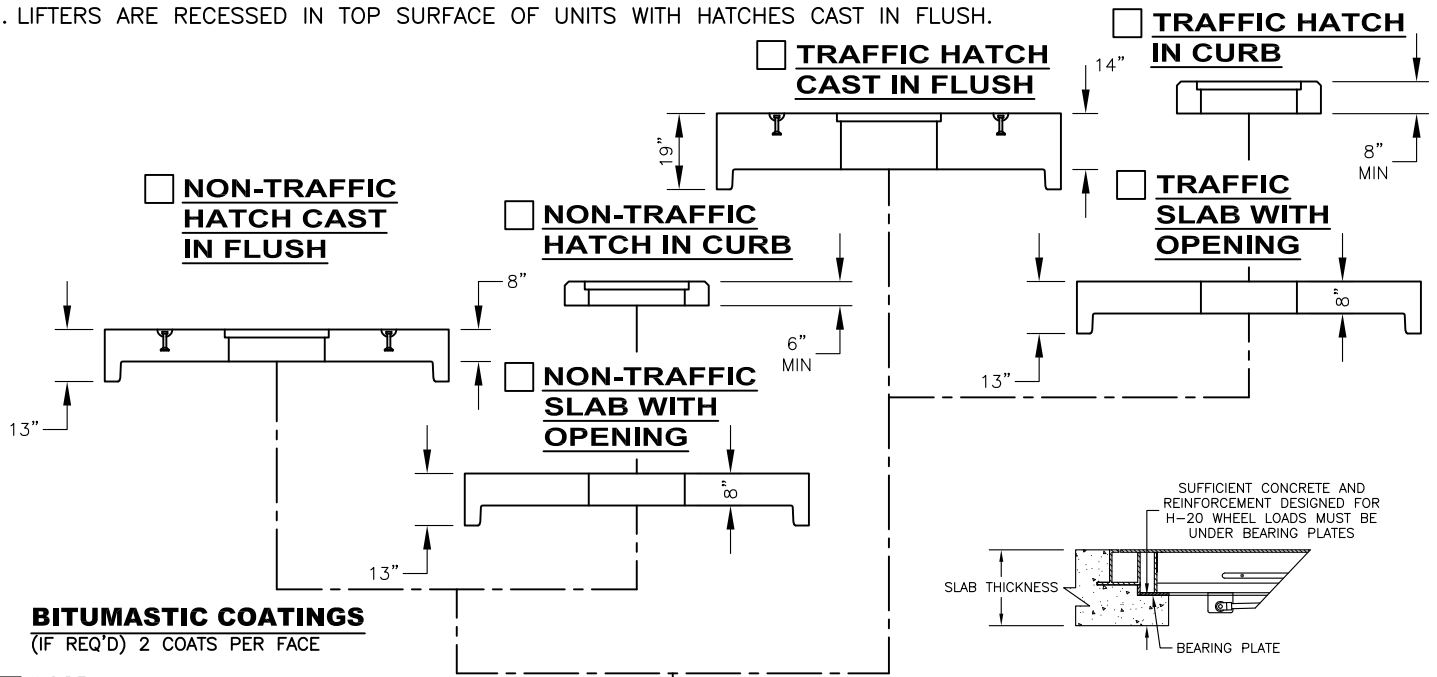

BITUMASTIC COATINGS
(IF REQ'D) 2 COATS PER FACE

- INSIDE
- OUTSIDE
- NONE

OPTIONAL BUTYL SEALANT IN ADDITION TO O-RING. MFG. RECOMMENDATION ONLY.

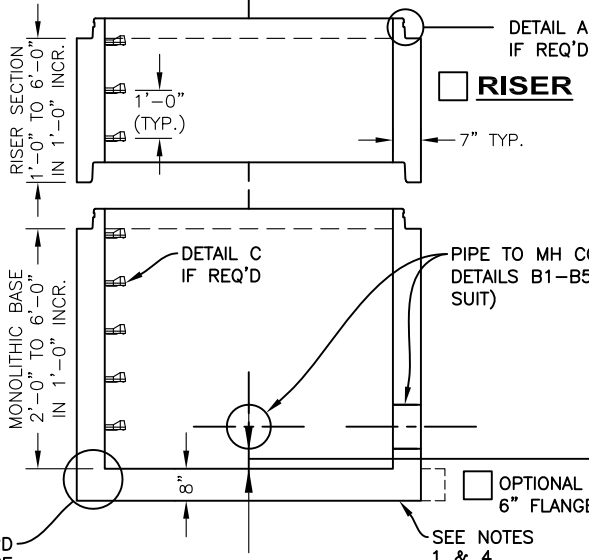

FLAT TOP SLAB IS STEEL REINFORCED TO MEET OR EXCEED HS-20 LOADING.

AVAILABLE OPENINGS

- 24" DIA.
- 24" SQ.
- 30" DIA.
- _____

VARIABLE SUMP

- 6" SUMP
- 12" SUMP
- 24" SUMP
- _____ SUMP

O-RING SECTION JOINT CONFORMS TO LATEST ASTM C443 SPEC.

NOTE: STEEL REINFORCED COPOLYMER POLYPROPYLENE PLASTIC STEP CONFORMS TO LATEST ASTM C478 SPEC.

<p>A</p> <p>6' DIA. RUBBER O-RING & BUTYL JOINT</p>	<p>B1</p> <p>HOLE - G.C. TO GROUT</p> <p>B2</p> <p>HOLE FOR LINKSEAL</p>	<p>B3</p> <p>DOGHOUSE PIPE TO FIT</p>	<p>B4</p> <p>WATERTIGHT BOOT</p>	<p>B5</p> <p>KNOCKOUT PIPE TO FIT</p>	<p>C</p> <p>PS2-PFS POLY-PROPYLENE STEP</p>
---------------------------------------------------------	--------------------------------------------------------------------------	---------------------------------------	----------------------------------	---------------------------------------	---------------------------------------------

C:\Drawings\New Stuff after 2-26-10\MANHOLES\6' DIA. MANHOLES\Types\Pump Station\MH6PS.DWG