



KISTNER CONCRETE PRODUCTS INC.
8713 READ ROAD
E. PEMBROKE, N.Y.
14056
(716) 894-2267

PRODUCT DESIGNATION

MANHOLE 10' DIA. STORM

DWG. NO.

MH10ST ©

5/23/12

GENERAL NOTES:

1. REINFORCED STEEL CONFORMS TO ASTM A185 SPEC. 0.30 in²/LF AND 0.30 in²/LF B/W IN BOT. SLAB 120" DIA. BARREL.
2. REINFORCED STEEL CONFORMS TO ASTM A185 SPEC. 0.12 in²/LF 48" DIA. BARREL.
3. CONCRETE COMPRESSIVE STRENGTH 4,000 PSI. MINIMUM.
4. MANHOLE DESIGN SPECIFICATIONS CONFORM TO LATEST ASTM C478 SPEC. FOR PRECAST REINFORCED CONCRETE MANHOLE SECTIONS.

FLAT TOP SLAB IS STEEL REINFORCED TO MEET OR EXCEED HS-20 LOADING.

AVAILABLE OPENINGS

- 24" DIA.
- 24" SQ.
- 30" DIA.
- _____

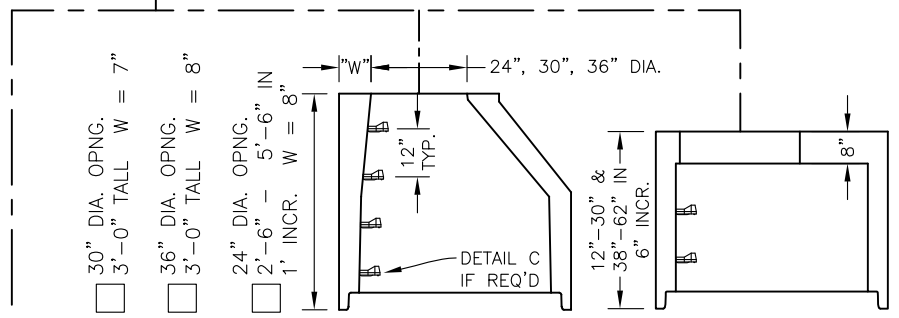
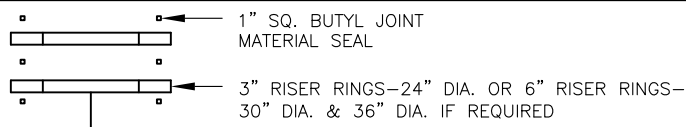

4' DIA. CONE 4' DIA. FLAT TOP

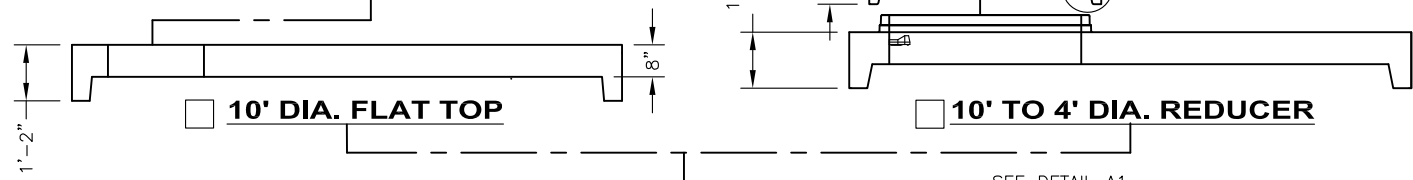
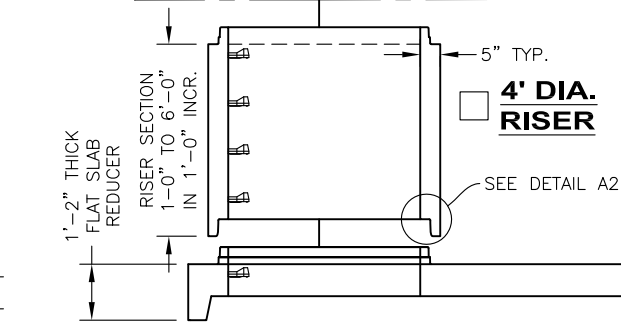

DIMENSION FROM INVERT TO START OF CONE

BITUMASTIC COATINGS

(IF REQ'D) 2 COATS PER FACE

- INSIDE
- OUTSIDE
- NONE
- OPTIONAL BUTYL SEALANT IN ADDITION TO O-RING. MFG. RECOMMENDATION ONLY. (10' JOINT ONLY)

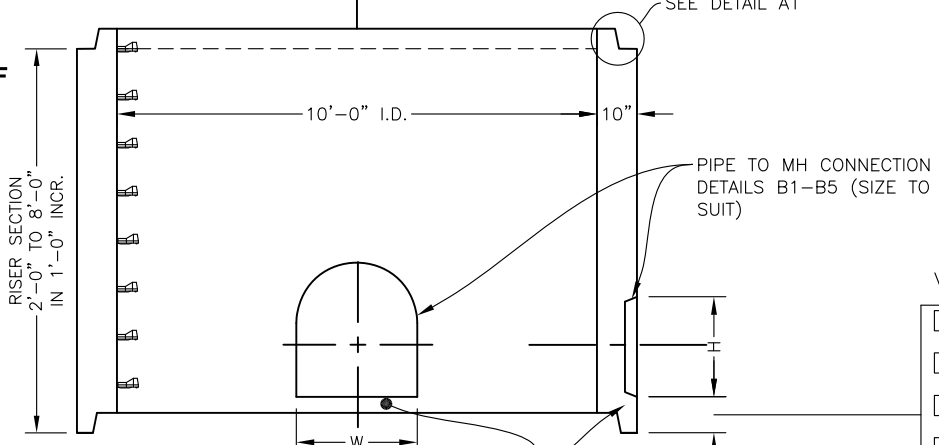

VARIABLE SUMP

- 6" SUMP
- 12" SUMP
- 24" SUMP
- _____ SUMP

***4" BEAM UNDER EACH DOGHOUSE. CONTRACTOR TO REMOVE IN FIELD

O-RING SECTION JOINT CONFORMS TO LATEST ASTM C443 SPEC. AND BUTYL CONFORMS TO FEDERAL SPEC. SS-S-210A.

STANDARD BASE

BASE SECTION TO BE SET PER JOB SPECIFICATIONS

OPTIONAL 6" FLANGE
SEE NOTE 1

NOTE: STEEL REINFORCED COPOLYMER POLYPROPYLENE PLASTIC STEP CONFORMS TO LATEST ASTM C478 SPEC.

<p>A1</p> <p>10' DIA. RUBBER O-RING & BUTYL JOINT</p>	<p>A2</p> <p>4' DIA. FACTORY LUBED OFFSET GASKET</p>	<p>B1</p> <p>HOLE-G.C. TO GROUT</p> <p>B2</p> <p>HOLE FOR LINKSEAL</p>	<p>B3</p> <p>WATERTIGHT BOOT</p>	<p>B4</p> <p>2"</p> <p>KNOCKOUT PIPE TO FIT</p>	<p>C</p> <p>PS2-PFS POLYPROPYLENE STEP</p>
---	--	--	----------------------------------	---	--