

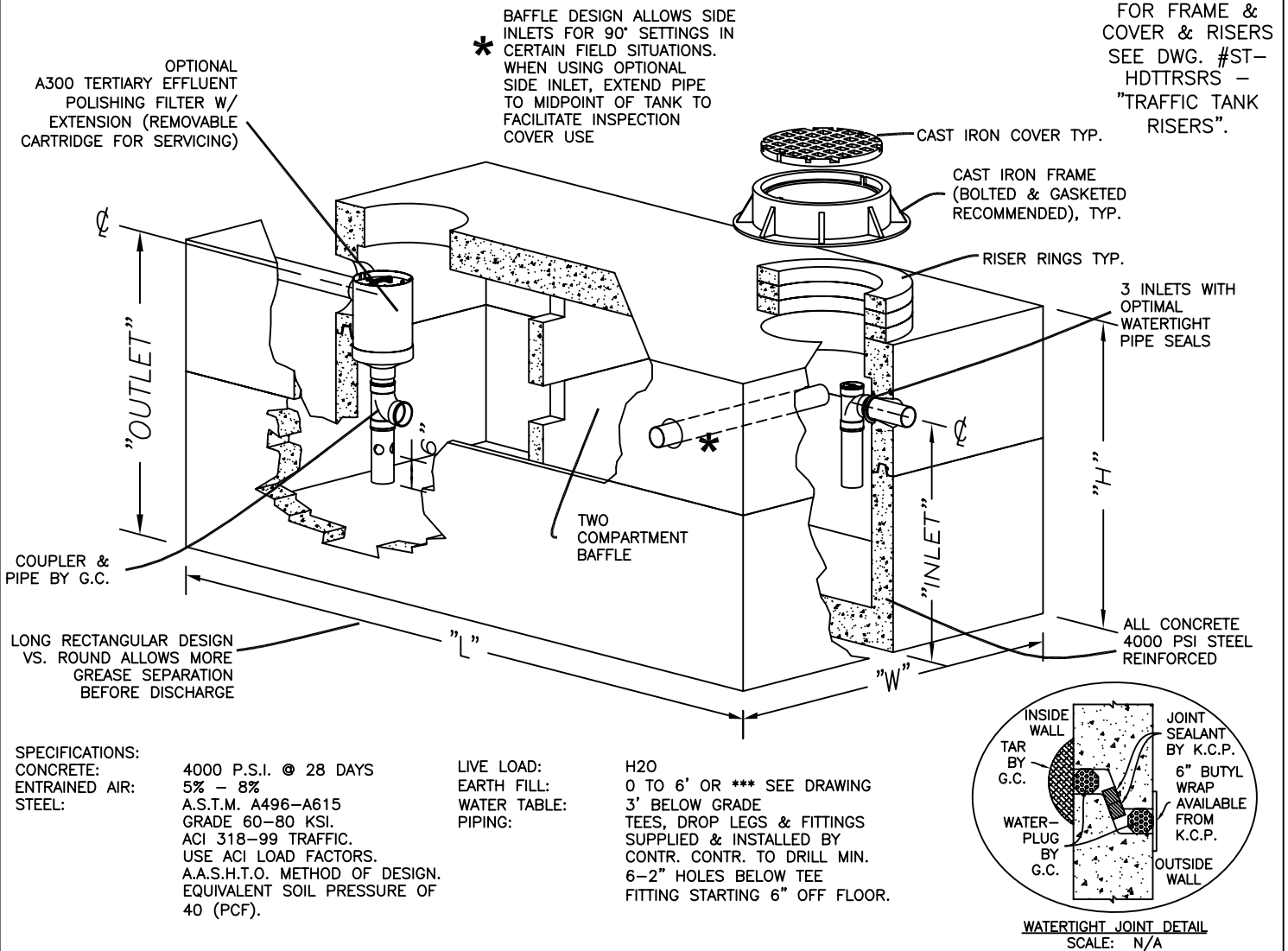

GREASE INTERCEPTORS - TRAFFIC



GREASE INTERCEPTORS - TRAFFIC							
DESCRIPTION	"L"	"W"	"H"	"INLET"	"OUTLET"	DWG. #	REVISION
** 350	60"	60"	60"	46"	44"	GI-KSEP-GI350T	1/19/2007
** 500	60"	60"	72"	61"	59"	GI-KSEP-GI500T	1/19/2007
1000	108"	66"	83"	68"	66"	GI-KSEP-GI1000T-II	1/19/2007
1250	108"	66"	86"	71"	68"	GI-KSEP-GI1250T	1/19/2007
1500	156"	84"	63"	49"	46"	GI-KSEP-GI1500T	1/19/2007
2000	156"	84"	77"	63"	60"	GI-KSEP-GI2000T	1/19/2007
2500	156"	84"	86"	72"	69"	GI-KSEP-GI2500T	1/19/2007
3100	156"	84"	100"	86"	83"	GI-KSEP-GI3100T	1/19/2007
3700	156"	84"	114"	100"	97"	GI-KSEP-GI3700T	1/19/2007
4100	156"	84"	128"	114"	111"	GI-KSEP-GI4100T	1/19/2007
5000 ***	156"	84"	142"	128"	125"	GI-KSEP-GI5000T	1/19/2007
6000 ***	156"	84"	170"	156"	153"	GI-KSEP-GI6000T	1/19/2007

** SINGLE COMPARTMENT, NO SIDE INLET.