

GRAVIX RETAINING WALL SYSTEM - Estimating Charts

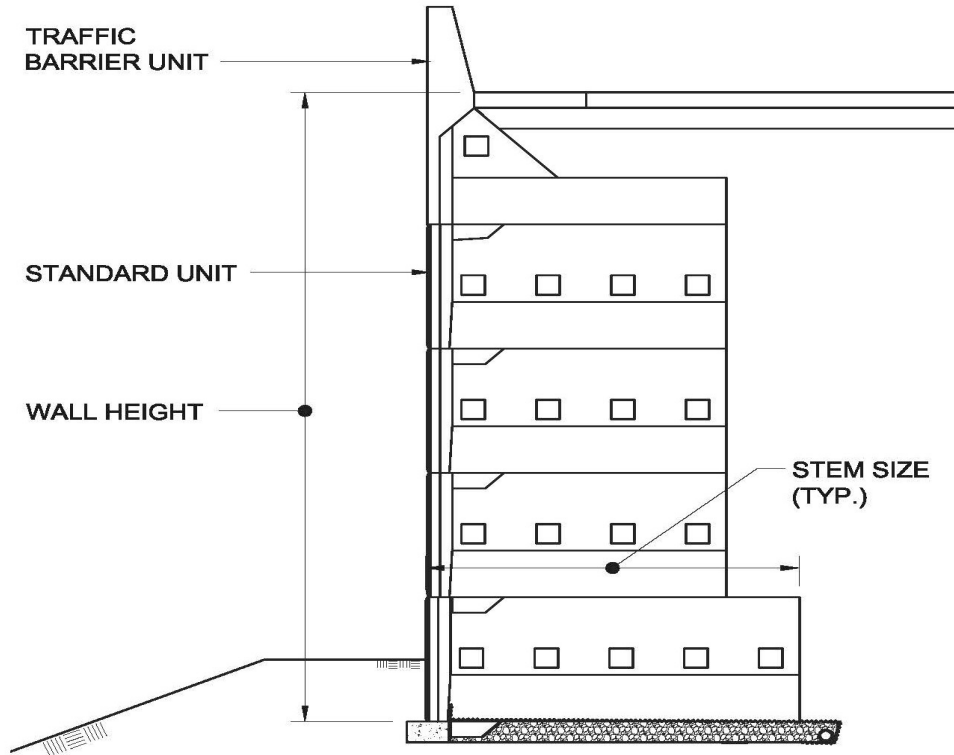

Roadway Surcharge, Backfill Unit Weight $\gamma = 120$ PCF

$\Phi = 30^\circ$ Soil Backfill

$\Phi = 36^\circ$ Gravel Backfill

Wall Height	Unit Stem Size Needed							
	TB	8'	10'	12'	14'	16'	18'	20'
4.0'	1							
8.0'	1	1						
12.0'	1	2						
16.0'	1	3						
20.0'	1	3	2					
24.0'	1	2	1	2				
28.0'	1	1	2	1	2			
32.0'	1	1	1	2	1	2		
36.0'	1	1	1	2	1	1	2	
40.0'	1	1	1	1	2	1	1	2

Wall Height	Unit Stem Size Needed							
	TB	8'	10'	12'	14'	16'	18'	20'
4.0'	1							
8.0'	1	1						
12.0'	1	2						
16.0'	1	3						
20.0'	1	4						
24.0'	1	4	1					
28.0'	1	3	2	1				
32.0'	1	3	2	1	1			
36.0'	1	3	2	1	1	1		
40.0'	1	3	2	1	1	1	1	

The soils effective friction angle and unit weight as outlined above is assumed to be used within, behind and beneath the retaining wall.

GRAVIX
DOT Precast Wall System

Earth Wall Products, LLC
Marietta, Georgia USA
Tel: 678.594.3451
www.earthwallproducts.com

The information contained herein has been compiled by Earth Wall Products, LLC and to the best of our knowledge, accurately represents the Gravix product use in the applications which are illustrated. Final determination of the suitability for the use contemplated and its manner of use are the sole responsibility of the user. Final structural design and analysis shall be performed by a qualified engineer.