



KISTNER CONCRETE PRODUCTS INC.
8713 READ ROAD
E. PEMBROKE, N.Y. 14056
(716) 894-2267

PRODUCT DESIGNATION

24" SQ. X 66" CATCH BASIN

DWG. NO.

CB-CB2466 ©
8/22/06

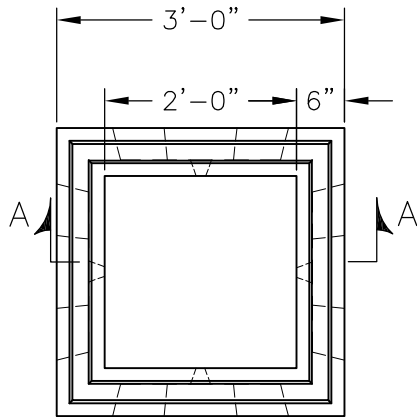

PLAN

SPECIFICATIONS:

CONCRETE: 4,000 PSI @ 28 DAYS
 ENTRAINED AIR: 5%-9%
 STEEL: ASTM A496-A615 GRADE 60-60 KSI
 DESIGN LOADING: AASHTO HS-20-44 WITH 30% IMPACT AND EQUIVALENT SOIL PRESSURE OF 30 PCF. FLOATATION FORCES NOT ACCOUNTED FOR.
 WEIGHT: 3282 LBS.
 KNOCKOUT: ALL KNOCKOUTS HAVE 2" - 2 1/2" CONCRETE THICKNESS.
 DRAIN HOLE: ALL UNITS HAVE 1" DRAIN HOLES IN EACH KNOCKOUT. CONTRACTOR TO GROUT IF NOT REQUIRED.

RAISED FRAME & GRATE

- CONTRACTOR TO SUPPLY
- 2" HIGH STEEL FRAME FOR R4832B GRATE
- 4" HIGH STEEL FRAME FOR R4832B GRATE
- 6" CAP WITH FRAME CAST IN FLUSH FOR R4832B GRATE

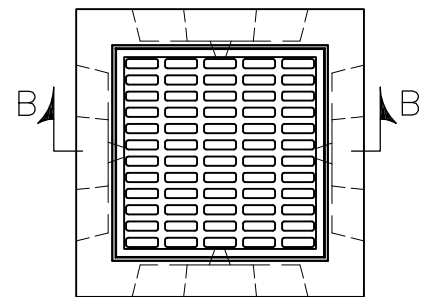

PLAN

BITUMASTIC COATING (IF REQUIRED)

- INTERIOR
- EXTERIOR
- NONE REQ'D
- RISER 6", 12", 18", 24", 36", 48"

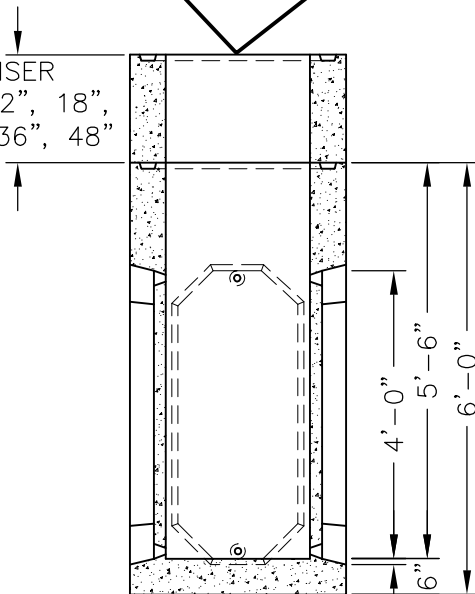

SECTION A-A

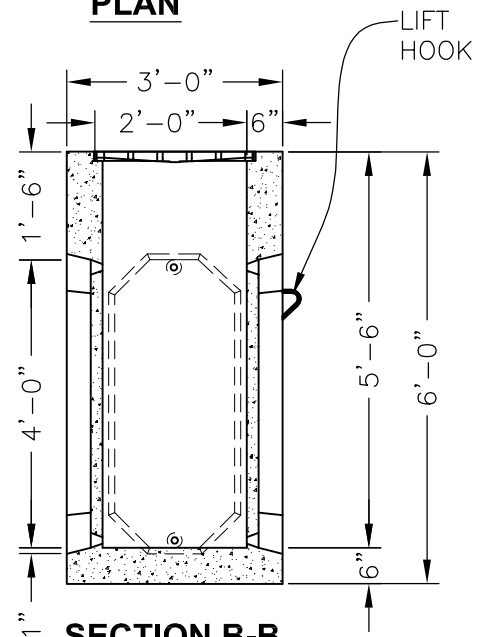

SECTION B-B

CODE: 315BT FRAME AND GRATE IN CAP OR RAISED STYLE TO BE USED.

CODE: 316BT WITH NEENAH R4832B GRATE OR EQUAL - HS-20-44 LOADING BICYCLE PROOF CAST IN FLUSH