



KISTNER CONCRETE PRODUCTS INC.
8713 READ ROAD
E. PEMBROKE, N.Y.
14056
(716) 894-2267

PRODUCT DESIGNATION

BOX CULVERT – STANDARD SHAPES
AND SKEWED END SECTION DATA

DWG. NO.

BC-SKSS

©

BELL OR SPIGOT
END MUST BE 90°

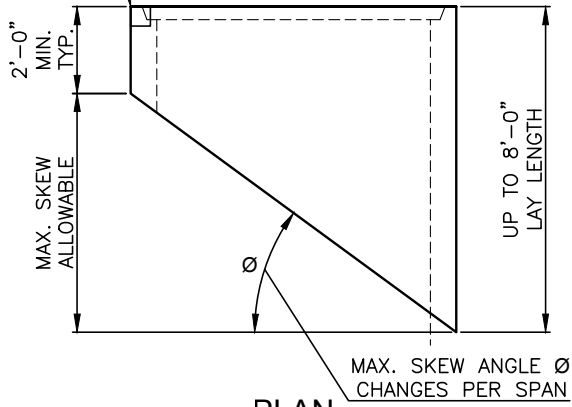

PLAN

Span (ft)	Wall Thickness (in)	Max Lay Length (ft)	∅ Max Road Skew Angle (Deg)
4	8	8	48
5	8	8	43
6	8	8	39
7	8	8	35
8	8	8	32
9	8	8	30
10	8	8	27
11	8	8	25
12	8	8	24
13	10	8	22
14	10	8	20
15	10	7.5	18
16	10	7.5	17
17	10	7.5	16
18	10	7	14
19	12	7	13
20	12	7	12
21	12	6.5	11
22	12	6.5	10
23	12	6.5	10
24	12	6	8

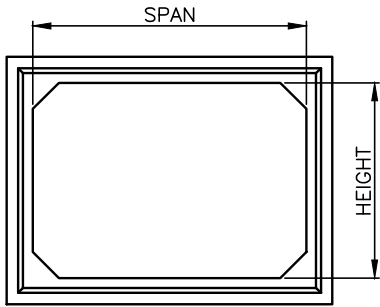

END VIEW



PROFILE

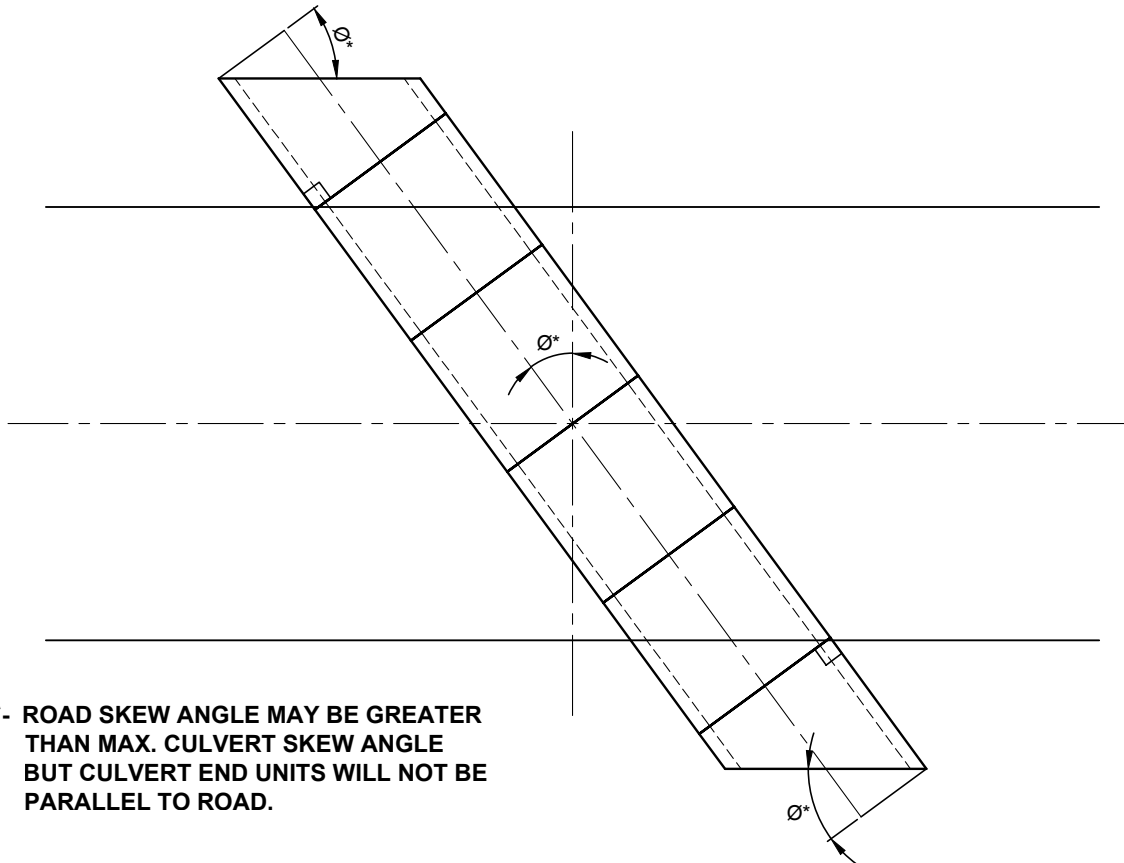

* - ROAD SKEW ANGLE MAY BE GREATER THAN MAX. CULVERT SKEW ANGLE BUT CULVERT END UNITS WILL NOT BE PARALLEL TO ROAD.

L:\CADD\PRODUCTS\SQUARE AND RECTANGULAR STRUCTURES\BOX CULVERTS\OLD BLUE CATALOG BC SHEETS\BCSKSS.dwg