



KISTNER CONCRETE PRODUCTS INC.
 8713 READ ROAD
 E. PEMBROKE, N.Y.
 14056
 (716) 894-2267

PRODUCT DESIGNATION

PRECAST 4' RADIUS GUTTER CONDUIT

DWG. NO.

BC-4GC
 9-9-91

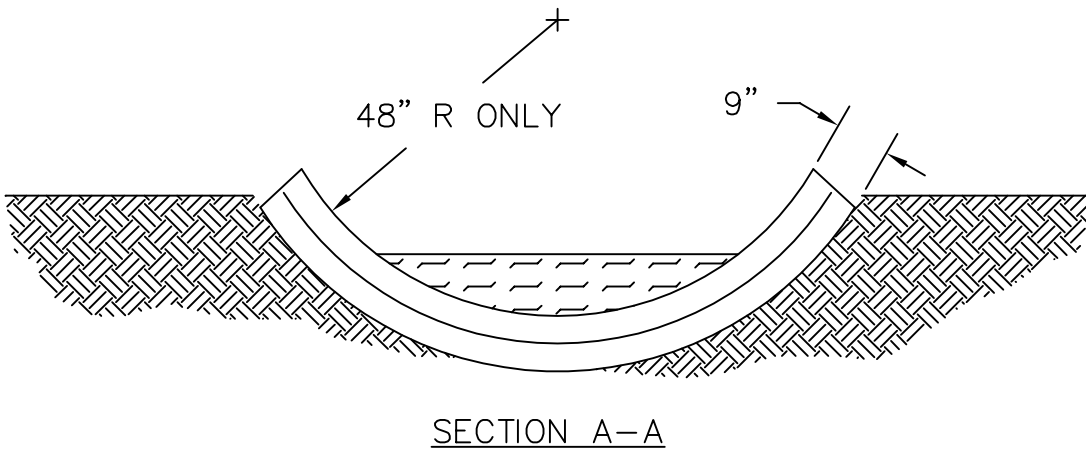
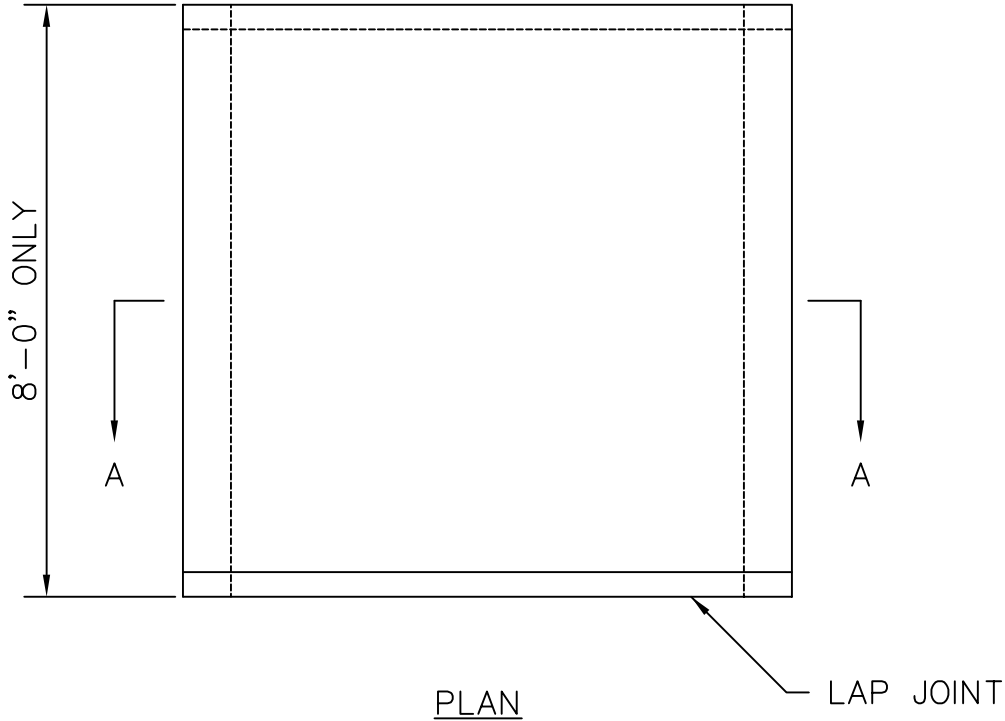

SPECIFICATIONS:

CONCRETE:	4000 P.S.I. @ 28 DAYS.
ENTRAINED AIR:	5% - 9%.
STEEL:	A.S.T.M. A496-A615 GRADE 60-60 KSI.
DESIGN LOADING:	A.A.S.H.T.O. HS-20-44 WITH 30% IMPACT AND EQUIVALENT SOIL PRESSURE OF 130 (PSI).